

# Sander Motors

## Standard 8 & 12, Super 8 & 12, American 8 & 12

- 4 HP 220V 1750 RPM

Motor Runs at Smooth Original RPM but with more  
Cutting Power, 2X the Torque of 3450 RPM Motors

- Sealed/Dust Less Motor
- Externally Fan Cooled
- Electronic Start Switch
- Capacitor Run
- Carry Handle
- Includes Motor, Drum, and Fan pulleys, Steel
- Includes V Belts, Drum and Fan
- OEM Style Motor Plate with Handle

We believe the original sanders run so well because of low speed high torque motors. This reduces vibration. Also V belts are available anywhere.

**Baldor Motor**



8" Super 8 **AS101A8**  
STD. 8 **AS101SD**  
12 American **AS101A2**

## Clarke 504, F-87, CF12

- Same Motor Features as Above
- Drop in Design for 504 Sanders
- Circuit Breaker ON/OFF Switch
- Pig Tail With Electric Plug
- Includes Motor, Drum, and Fan pulleys, Steel
- Includes V Belts, Drum and Fan

504- F87 -8"  
CS101  
CF12 12"  
CS101PC

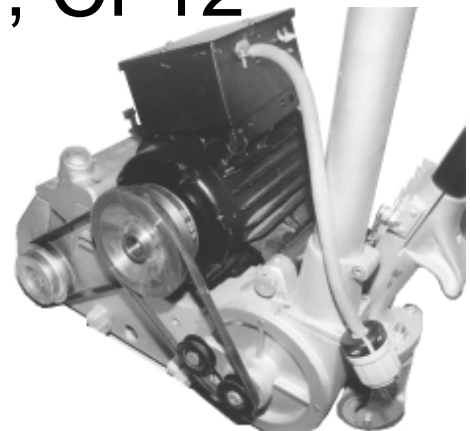

## F - 89

- 3 HP 110/220V Motor
- Or 4HP Baldor Motor, Larger Motor 220V only
- Drop in Design for F-89 Sanders
- Circuit Breaker ON/OFF Switch
- Pig Tail With Electric Plug
- Includes Motor, Drum, and Fan pulleys, Steel
- Includes V Belts, Drum and Fan

CS101FB  
CS101FG

**Call For Price**

